

# 51R85G LABEL INSPECTION

The 51R8G provides 360-degree inspection of labeled products, including but not limited to beverages, sauces, and household goods. With a multi-camera inspection at speeds up to 1000 containers per minute, this system accurately detects label, labeling errors, and cap integrity to ensure your product best represents itself and your brand on the shelf.

**INSPECTIONS INCLUDE:**

Label Folds, Tears, Splices, and Incorrect Labels

Spliced and Skewed Labels, Wrong & Missing Labels

Label Height and Other Application Defects

Cap Integrity: Cocked or Missing Caps, Missing Tamper Band



The world's most trusted brands trust Silgan to be their Partner for Innovation

## WHY CHOOSE THE SILGAN 51R85G?



**Simplicity:** Installs easily over existing conveyor, saving valuable floor space. The user interface simplifies changeovers and new job setups.

**Efficiency:** 100% product inspection prevents defects from going downstream. The proprietary system intelligence prevents poor product runs that result in costly spoilage.

**Reliability:** The stainless steel, NEMA 4X design, withstands food and beverage plant environments. Our dedicated technical service team is there for all your inspection needs and our optional service agreement program makes it all hassle-free.

Want To Know More?



[sales@silganequipment.com](mailto:sales@silganequipment.com)

# 51R85G TECHNICAL SPECIFICATIONS

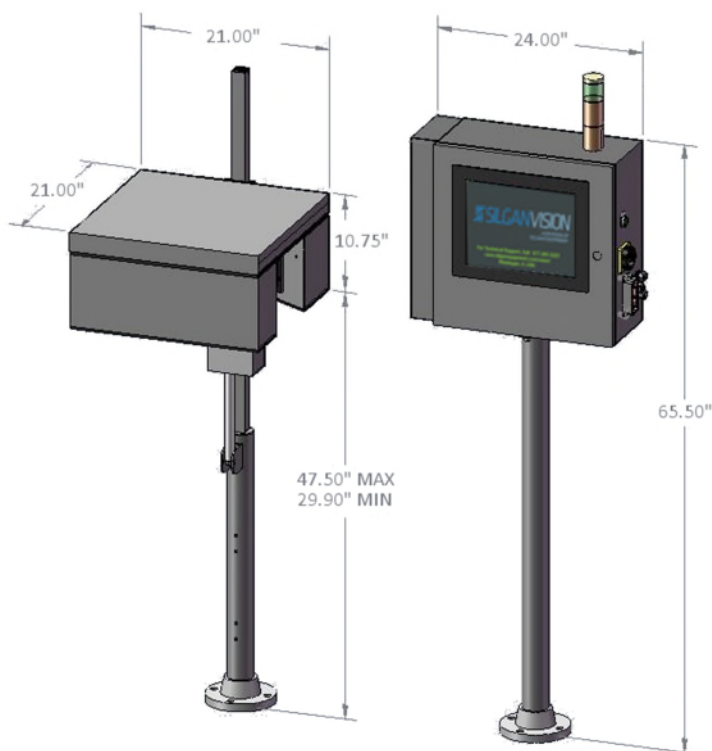

<b>Model</b>	51R85G Label Inspection
<b>Cap Sizes</b>	Ø28mm – Ø82mm
<b>Camera Configuration</b>	Multi-Camera for 360° Label Inspection
<b>Interface</b>	15" Touch Screen
<b>Cap Integrity</b>	Camera Limited Cap Inspection
<b>Other Features</b>	<ul style="list-style-type: none"> <li>• Custom LED Lighting</li> <li>• Solid State Hard Drive with Backup</li> <li>• Motorized Tunnel Height Adjustment</li> <li>• Cabinet Cooler for Temperature Control</li> <li>• Ethernet Bay for Online Connectivity</li> <li>• Password Protect Feature</li> <li>• Teach Function for Auto Configuration</li> <li>• Saves up to 70 Recipes / Jobs</li> <li>• Status Billboard for Real-Time Data</li> </ul>
<b>NEMA Rating</b>	4X - Watertight (Wash-Down Environment)
<b>Electrical Requirements</b>	120VAC 1 Phase
<b>Environment Temp.</b>	33° ~ 115°F
<b>Space Required (x2)</b>	Height: 65.5 Inches Width: 24 Inches Depth: 21 Inches

**Choose From These Great Options:**

<b>Tap Touch 600 Pneumatic Ejector (NEMA 4)</b>	<b>Control Cabinet Cover</b>
<b>Soft Touch Diverter (NEMA 4X)</b>	<b>Paxton Cap Dryer</b>
<b>UPS &amp; Surge Protector (NEMA 4X)</b>	<b>Sleever Tracker</b>

### Why Choose Silgan Equipment?

- Silgan's expertise and leadership has served our customers for over 20 years with inspection solutions.
- Today, Silgan Equipment business partners exceed their standards for quality and support world-wide. Many of the top food and beverage processors rely on us for their quality assurance programs.
- With our 24/7 support line and full-service technicians located throughout the continental US, we stand by our products and help you get the best out of your operation.
- Silgan Equipment is a proud member of the Silgan family of companies. We deliver the best-in-class service you deserve. We know your packaging and can help you grow.

*LET US HELP TAKE YOUR BUSINESS TO THE NEXT LEVEL!*

- Capping**
- Material Handling**
- ★ Quality Inspection**
- Rebuild & Engineering Services**

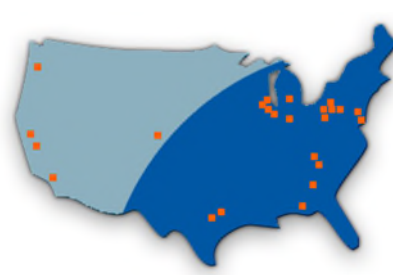

**Take Advantage of Silgan's Large U.S. Service Network**

**To start improving your productivity, call: 847.336.0552**