

## SOFT TOUCH 600 DIVERTER

The Soft Touch 600 is designed with your quality efforts in mind, offering a safe and reliable way to divert bottles and jars, minimizing product loss, damage to packaging, and messy cleanup. Whether you're removing defects, sampling quality, or diverting product-stream the Soft Touch 600 helps keep production on-track.

### FEATURES:

Graduated Fingers Gently Divert Containers

Speed Compensation Technology

Stainless Steel Construction for Enhanced Durability

Integrated Controls for Independent Programming



The world's most trusted brands trust Silgan to be their Partner for Innovation



## WHY CHOOSE THE SILGAN SOFT TOUCH?

**Simplicity:** Installs easily over existing conveyor, saving valuable floor space. The user interface simplifies changeovers and new job setups.

**Efficiency:** 100% product inspection prevents defects from going downstream. The proprietary system intelligence prevents poor product runs that result in costly spoilage.

**Reliability:** The stainless steel, NEMA 4X design, withstands food and beverage plant environments. Our dedicated technical service team is there for all your inspection needs and our optional service agreement program makes it all hassle-free.

Want To Know More?



[sales@silganequipment.com](mailto:sales@silganequipment.com)

# SOFT TOUCH 600 TECHNICAL SPECIFICATIONS

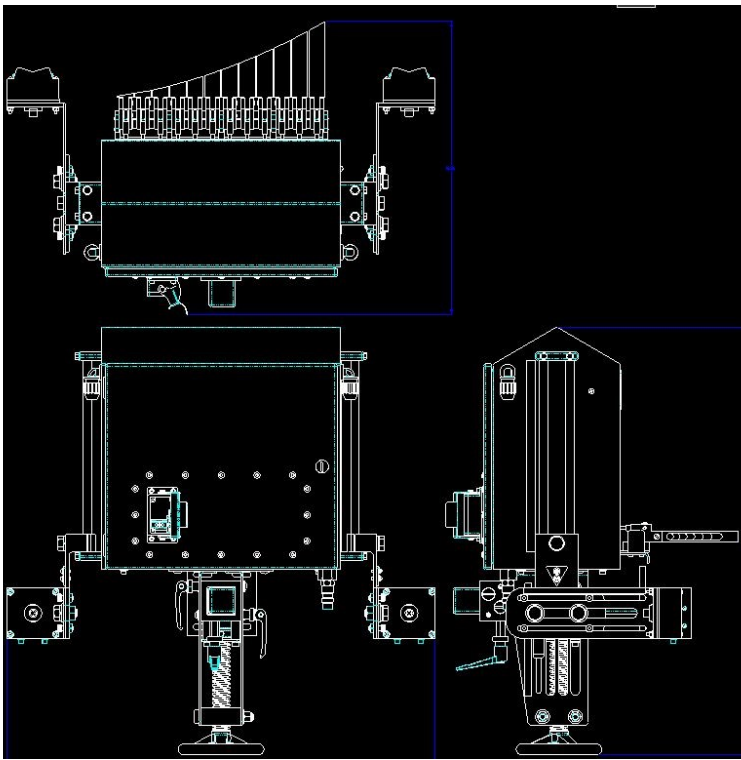

Model	SOFT Touch 600
How It Works	<ol style="list-style-type: none"> <li>1. Signal Received From Sensor or Upstream Operation</li> <li>2. Product is Tracked on Variable Speed Conveyor</li> <li>3. Diversion Profile is Calculated on Conveyor and Product Data</li> <li>4. Product is Diverted</li> </ol>
Speed	600 Containers Per Minute
Container Weight	Up to 0.5 lb. Total Weight
Container Types	Metal, Glass, Plastic
Air Requirements	100 PSI, 35 SCFM Depends on Application
NEMA Rating	4 - Watertight (Wash-Down Environment)
Electrical Requirements	120VAC 1 Phase
Environment Temp.	33° ~ 115°F
Space Required	Height : 19 Inches Width : 14 Inches Depth : 9.5 Inches

Choose From These Great Options:

Encoder With Cable	Software Upgrades:
5.7" HMI (3.5" HMI is Standard)	<ul style="list-style-type: none"> <li>• Speed Compensation</li> </ul>
Sync Sensor with Cordset	<ul style="list-style-type: none"> <li>• QC Sampling</li> </ul>
	<ul style="list-style-type: none"> <li>• Product Synchronizing</li> </ul>

## Why Choose Silgan Equipment?

- Silgan's expertise and leadership has served our customers for over 20 years with inspection solutions.
- Today, Silgan Equipment business partners exceed their standards for quality and support world-wide. Many of the top food and beverage processors rely on us for their quality assurance programs.
- With our 24/7 support line and full-service technicians located throughout the continental US, we stand by our products and help you get the best out of your operation.
- Silgan Equipment is a proud member of the Silgan family of companies. We deliver the best-in-class service you deserve. We know your packaging and can help you grow.

LET US HELP TAKE YOUR BUSINESS TO THE NEXT LEVEL!

Capping

Material Handling

★ Quality Inspection

Rebuild & Engineering Services

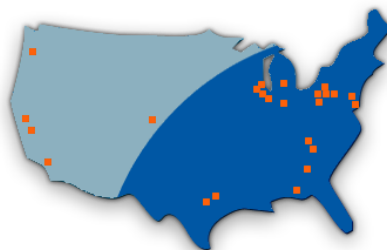

Take Advantage of Silgan's Large U.S. Service Network

To start improving your productivity, call: 847.336.0552