

51R85S LABEL INSPECTION

The 51R85S provides 360-degree inspection of labeled products, including but not limited to beverages, sauces, and household goods. With a multi-camera inspection at speeds up to 1000 containers/min, this system accurately detects label, labeling errors, and cap integrity to ensure your product best represents itself and your brand on the shelf.

INSPECTIONS INCLUDE:

Label Folds, Tears, Splices, and Incorrect Labels

Spliced and Skewed Labels, Wrong & Missing Labels

Label Height and Other Application Defects

Cap Integrity: Cocked or Missing Caps, Missing Tamper Band

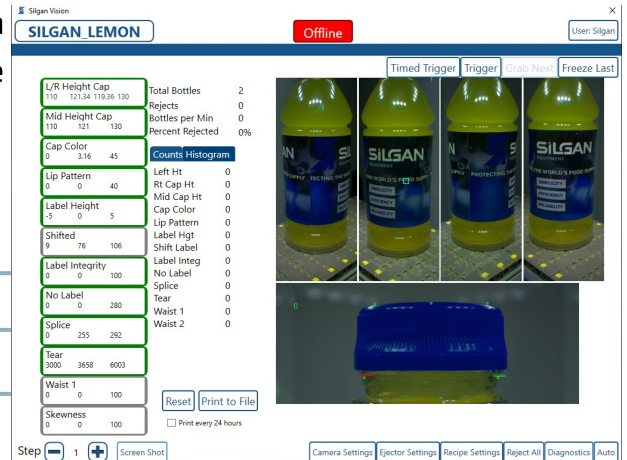

The world's most trusted brands trust Silgan to be their Partner for Innovation

WHY CHOOSE THE SILGAN 51R85S?



Simplicity: Installs easily over existing conveyor, saving valuable floor space. The user interface simplifies changeovers and new job setups.

Efficiency: 100% product inspection prevents defects from going downstream. The proprietary system intelligence prevents poor product runs that result in costly spoilage.

Reliability: The stainless steel, NEMA 4X design, withstands food and beverage plant environments. Our dedicated technical service team is there for all your inspection needs and our optional service agreement program makes it all hassle-free.

Want To Know More?



sales@silganequipment.com

www.silganequipment.com | 847.336.0552 | 1301 W. DUGDALE RD, WAUKEGAN, IL 60085

51R85S TECHNICAL SPECIFICATIONS

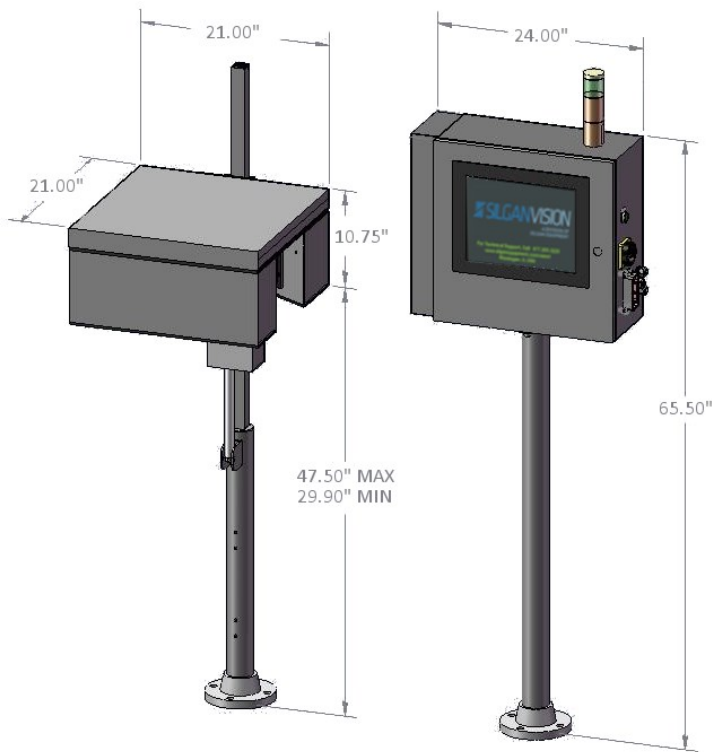

Model	51R85S Label Inspection
Cap Sizes	Ø28mm – Ø82mm
Camera Configuration	Multi-Camera for 360° Label Inspection
Interface	15" Touch Screen
Cap Integrity	Camera Limited Cap Inspection
Other Features	<ul style="list-style-type: none"> • Custom LED Lighting • Solid State Hard Drive with Backup • Motorized Tunnel Height Adjustment • Cabinet Cooler for Temperature Control • Ethernet Bay for Online Connectivity • Password Protect Feature • Teach Function for Auto Configuration • Saves up to 70 Recipes / Jobs • Status Billboard for Real-Time Data
NEMA Rating	4X - Watertight (Wash-Down Environment)
Electrical Requirements	120VAC 1 Phase
Environment Temp.	33° ~ 115°F
Space Required (x2)	Height: 65.5 Inches Width: 24 Inches Depth: 21 Inches

Choose From These Great Options:

Tap Touch 600 Pneumatic Ejector (NEMA 4)

Control Cabinet Cover

Soft Touch Diverter (NEMA 4X)

Paxton Cap Dryer

UPS & Surge Protector (NEMA 4X)

Sleever Tracker

Why Choose Silgan Equipment?

- Silgan's expertise and leadership has served our customers for over 20 years with inspection solutions.
- Today, Silgan Equipment business partners exceed their standards for quality and support world-wide. Many of the top food and beverage processors rely on us for their quality assurance programs.
- With our 24/7 support line and full-service technicians located throughout the continental US, we stand by our products and help you get the best out of your operation.
- Silgan Equipment is a proud member of the Silgan family of companies. We deliver the best-in-class service you deserve. We know your packaging and can help you grow.

LET US HELP TAKE YOUR BUSINESS TO THE NEXT LEVEL!

Capping

Material Handling

★ Quality Inspection

Rebuild & Engineering Services

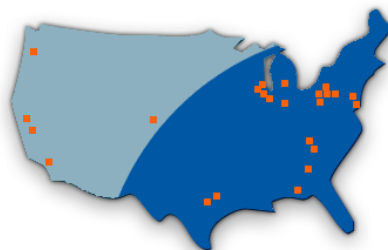

Take Advantage of Silgan's Large U.S. Service Network

To start improving your productivity, call: 847.336.0552